

CYL49F Linear Hall Effect Sensor

General Description

The CYL49F is a small, versatile linear Hall-effect device that is operated by the magnetic field from a permanent magnet or an electromagnet. The output voltage is set by the supply voltage and varies in proportion to the strength of the magnetic field. The integrated circuitry features low noise output, which makes it unnecessary to use external filtering. It also includes precision resistors to provide increased temperature stability and accuracy. The operating temperature range of this linear Hall sensor is -40°C to 105°C , appropriate for commercial, consumer and industrial applications.

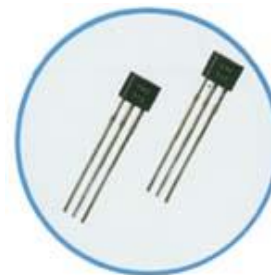

Features

- Miniature Construction
- Power Consumption of 3mA at $V_{CC}=5\text{V}$ for Energy Efficiency
- Single Current Sourcing Output
- Linear Output for Circuit Design Flexibility
- Low Noise Output Virtually Eliminates the Need for Filtering
- A Stable and Accurate Output
- Temperature Range of -40°C to 105°C
- Responds to Either Positive or Negative Magnetic Field
- The Maximum Instantaneous Supply Voltage up to 50V
- High ESD Rating: Human Body Model: 6000V, Machine Model: 600V

Typical applications

- Current Sensing
- Motor Control
- Position Sensing
- Magnetic Code Reading
- Ferrous Metal Detector
- Vibration Sensing
- Liquid Level Sensing
- Weight Sensing
- Pole Detection

Functional Block Diagram

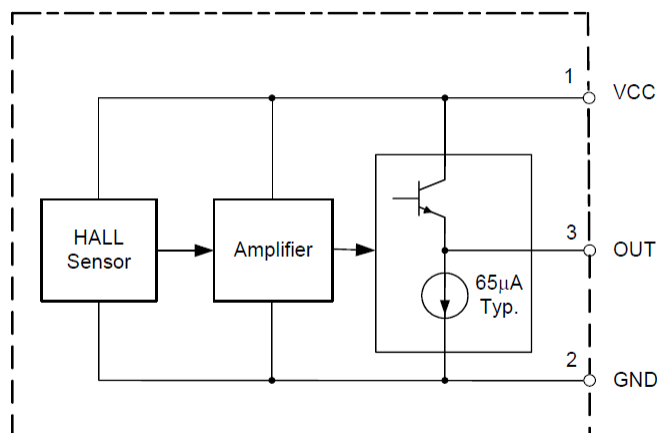

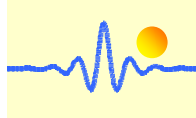

ABSOLUTE MAXIMUM RATINGS

Parameter	Symbol	Value	Unit
Supply Voltage	V _{CC}	2.7-10	V
Operating Temperature Range	T _A	-40 ~ 105	°C
Storage Temperature Range	T _S	-50 ~ 150	°C
ESD (Human Body Model)		6000	V
ESD (Machine Model)		600	V

Note: Stresses greater than those listed under "Absolute Maximum Ratings" may cause permanent damage to the device. These are stress ratings only. Functional operation of the device at these or any other conditions beyond those indicated under "Recommended Operating Conditions" is not implied. Exposure to "Absolute Maximum Ratings" for extended periods may affect device reliability.

Recommended Operating Conditions

Supply Voltage V_{CC}: 3~8V
Operating Temperature Range T_A: -40~105°C

Electrical & Magnetic Characteristics (T_A=25°C, V_{CC}=5.0V)

Parameter	Symbol	Conditions	Min	Typ	Max	Unit
Supply Current	I _{CC}		2	3	4	mA
Quiescent Output Voltage	V _O	@ B=0GS	2.25	2.5	2.75	V
Output Voltage Sensitivity	S	B=0 to ±600GS	1.7	2.0	2.4	mV/GS
Output Voltage Span	V _{OS}		1.0 to (V _{CC} -1.0)	0.8 to (V _{CC} -0.8)		V
Output Resistor	R _O			60	120	Ω
Magnetic Field Range	B		±500	±800		GS
Linearity of Span				0.7		%
Output Noise		BW=10Hz to 10kHz		90		μV

Connection

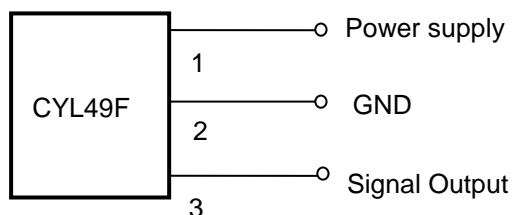

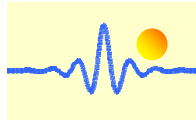

Package TO-92S (unit :mm)

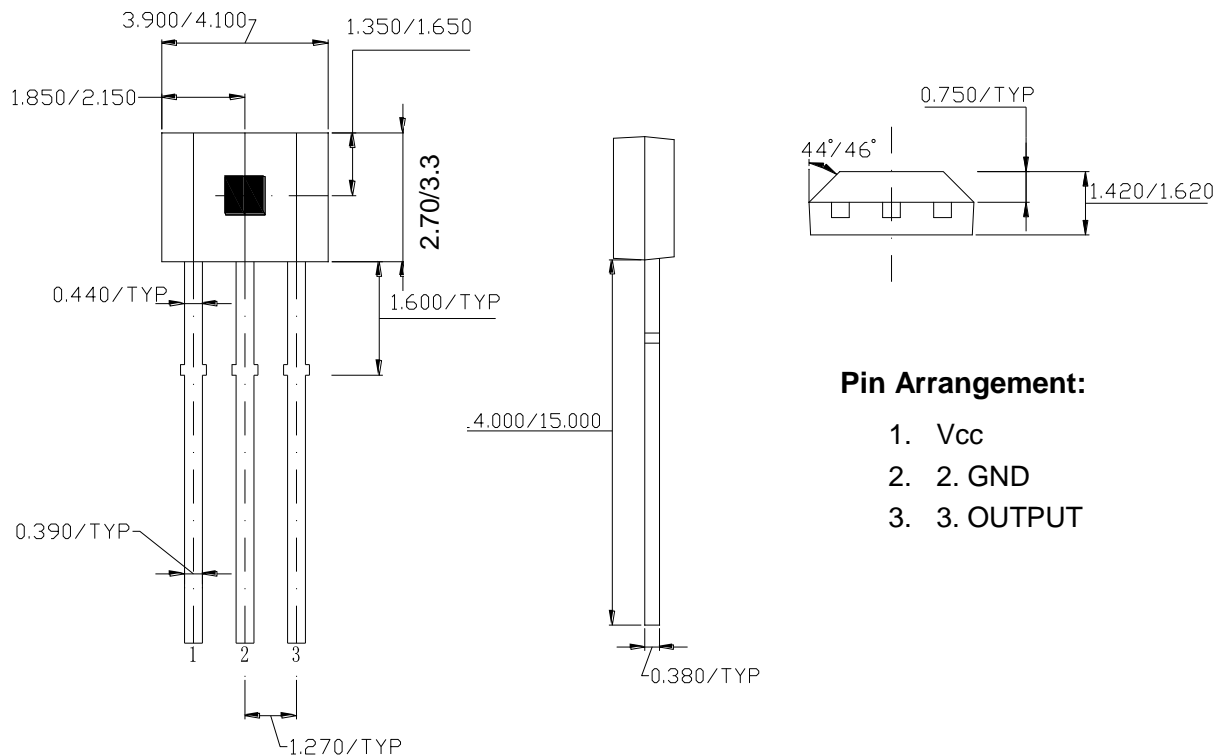

Pin Arrangement:

1. Vcc
2. GND
3. OUTPUT

Transfer Characteristics (VCC=5V)

When there is no outside magnetic field ($B=0GS$), the quiescent output voltage is one-half of the supply voltage in general. If a south magnetic pole approaches to the front face (the side with marking ID) of the Hall Effect sensor, the circuit will drive the output voltage higher. Contrary, a north magnetic pole will drive the output voltage lower. The variations of voltage level up or down are symmetrical. Greatest magnetic sensitivity is obtained with a supply voltage of 6V, but at the cost of increased supply current and a slight loss of output symmetry. So, it is not recommended to work in such condition unless the output voltage magnitude is a main issue. The output signal can be capacitively coupled to an amplifier for boosting further if the changing frequency of the magnetic field is high.

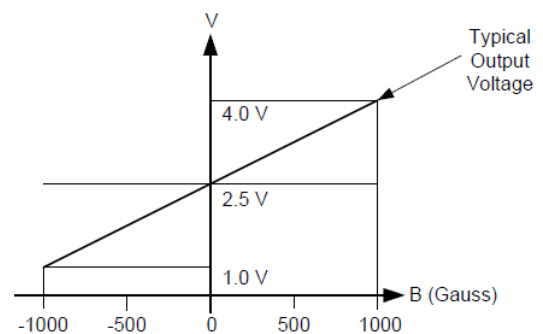

Note:

- Mechanical Stress Should be lessened as far as possible in the process of assembly
- The soldering temperature at the leads should be less than 260°C with 5 seconds.
- If N pole is approaching hall-effect ICs from the back side of the package, output voltage will increase, S pole is approaching ICs from the back side, output voltage will reduce; and if from the branded side of the package, the output situation is just to the contrary.