

## Self-Adjusting Hall Effect Gear Tooth Sensor IC CYGTS9802 with Complementary Output

The CYGTS9802 is a sophisticated IC featuring an on-chip 12-bit A/D Converter and logic that acts as a digital sample and hold circuit. A separate 6-bit D/A converter provides a fixed hysteresis. The sensor does not have a chopper delay. It uses a single Hall plate which is immune to rotary alignment problems. The bias magnet can be from 1000GS to 4000Gs. As the signal is sampled, the logic recognizes an increasing or decreasing flux density. The OUT will turn on (BOP) after the flux has reached its peak and decreased by an amount equal to the hysteresis. Similarly the OUT will turn off (BRP) after the flux has reached its minimum value and increased by an amount equal to the hysteresis. The complementary outputs (OUT and OUTB) are provided in this sensor. The OUTB will turn off after the flux has reached its peak and decreased by an amount equal to the hysteresis. Similarly the OUTB will turn on after the flux has reached its minimum value and increased by an amount equal to the hysteresis.

### Features

- High sensitivity
- Complementary output signal
- True zero speed detection
- Short circuit protection
- Insensitive to orientation
- Wide voltage working range
- Self-adjusting magnetic range
- On-chip 12 bit A/D converter
- High speed operation
- No chopper delay applications
- RoHS compliant

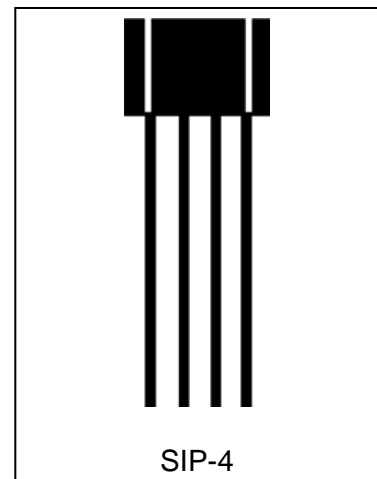

### Applications

#### Automotive and Heavy Duty Vehicles:

- Camshaft and crankshaft speed and position
- Transmission speed
- Tachometers
- Anti-skid/traction control

#### Industrial Areas:

- Sprocket speed
- Chain link conveyor speed/distance
- Stop motion detector
- High speed low cost proximity
- Tachometers, counters.

### Magnetic Specifications

DC Operating Parameters  $T_A = -40^{\circ}\text{C}$  to  $150^{\circ}\text{C}$ ,  $V_{DD} = 4.0\text{V}$  to  $24\text{V}$  (unless otherwise specified)

Parameter	Symbol	Test Conditions	Min	Typ	Max	Units
Back Bias Range	$B_{BIAS}$	Operating	-30	--	4000	Gs
Linear Region		$V_{DD} = 12\text{V}$	500	--	5000	Gs
Hysteresis	$B_{hys}$		10	--	80	Gs

10Gs=1mT

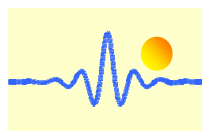

## Electrical Specifications

DC Operating Parameters  $T_A = -40^{\circ}\text{C}$  to  $150^{\circ}\text{C}$ ,  $V_{DD} = 4.0\text{V}$  to  $24\text{V}$  (unless otherwise specified)

Parameter	Symbol	Test Conditions	Min	Typ	Max	Unit
Supply Voltage	$V_{DD}$	Operating	4.0	12	24	V
Supply Current	$I_{DD}$	$V_{DD} = 12\text{V}$	1.5	3.0	4.5	mA
Power-Up State	$POS_{(OUT)}$	$V_{DD} > V_{DD(\text{min})}$	H	H	H	
	$POS_{(OUTB)}$		L	L	L	
Supply Current	$I_{DD}$	$V_{DD} = 4.0\text{V}$ to $30\text{V}$	1.0	--	6.0	mA
Leakage Current	$I_{LEAK}$	$V_{OUT} = 4.0\text{V}$ to $30\text{V}$	--	--	10	$\mu\text{A}$
Output Current	$I_{OUT}$	Operating	--	--	25	mA
Output Saturation Voltage	$V_{SAT}$	$V_{DD} = 12\text{V}$ , $I_{OUT} = 25\text{mA}$	--	--	600	mV
Output Current Limit	$I_{Limit}$	$V_{DD} = 12\text{V}$	50	100	150	mA
Output Short Circuit Shutdown	$T_{FAULT}$	Fault	10		20	$\mu\text{s}$
Clock Frequency	$F_{clk}$	Operating	400	500	600	KHz
Output Rise Time	$T_r$	$V_{DD}=12\text{V}$ , $R_1 = 1.0\text{K}$ , Load= $10\text{pF}$	--	--	400	nS
Output Fall Time	$T_f$	$V_{DD}=12\text{V}$ $R_1 = 1.0\text{K}$ , Load= $10\text{pF}$	--	--	400	nS
Bandwidth	BW	Operating	--	--	15	KHz
Thermal Resistance	RTH	Operating	--	--	200	$^{\circ}\text{C}/\text{Watt}$

## Absolute Maximum Ratings

Parameter	Limit Values	
	Min.	Max.
Supply Voltage (Operating), $V_{DD}$	-0.3V	30V
Output Voltage, $V_o$	-0.3V	30V
Supply Current (Fault), $I_{DD}$	--	50mA
Output Current (Fault), $I_{OUT}$	--	30mA
Output Current (Fault), $I_{fault}$	--	200mA
Junction temperature, $T_J$ (5000h)	--	150 $^{\circ}\text{C}$
Junction temperature, $T_J$ (2000h)	--	160 $^{\circ}\text{C}$
Junction temperature, $T_J$ (1000h)	--	170 $^{\circ}\text{C}$
Junction temperature, $T_J$ (100h)	--	180 $^{\circ}\text{C}$
Operating Temperature Range, $T_A$	- 40 $^{\circ}\text{C}$	150 $^{\circ}\text{C}$
Storage Temperature Range, $T_s$	- 65 $^{\circ}\text{C}$	150 $^{\circ}\text{C}$

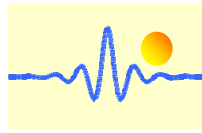

## ESD (Emergency Shutdown System) Protection

Human Body Model (HBM) tests

Parameter	Symbol	Max.	Unit	Note
ESD	$V_{ESD}$	8	kV	According to standard EIA/JESD22-A114-B HBM

## Application Circuit and Pin Configuration

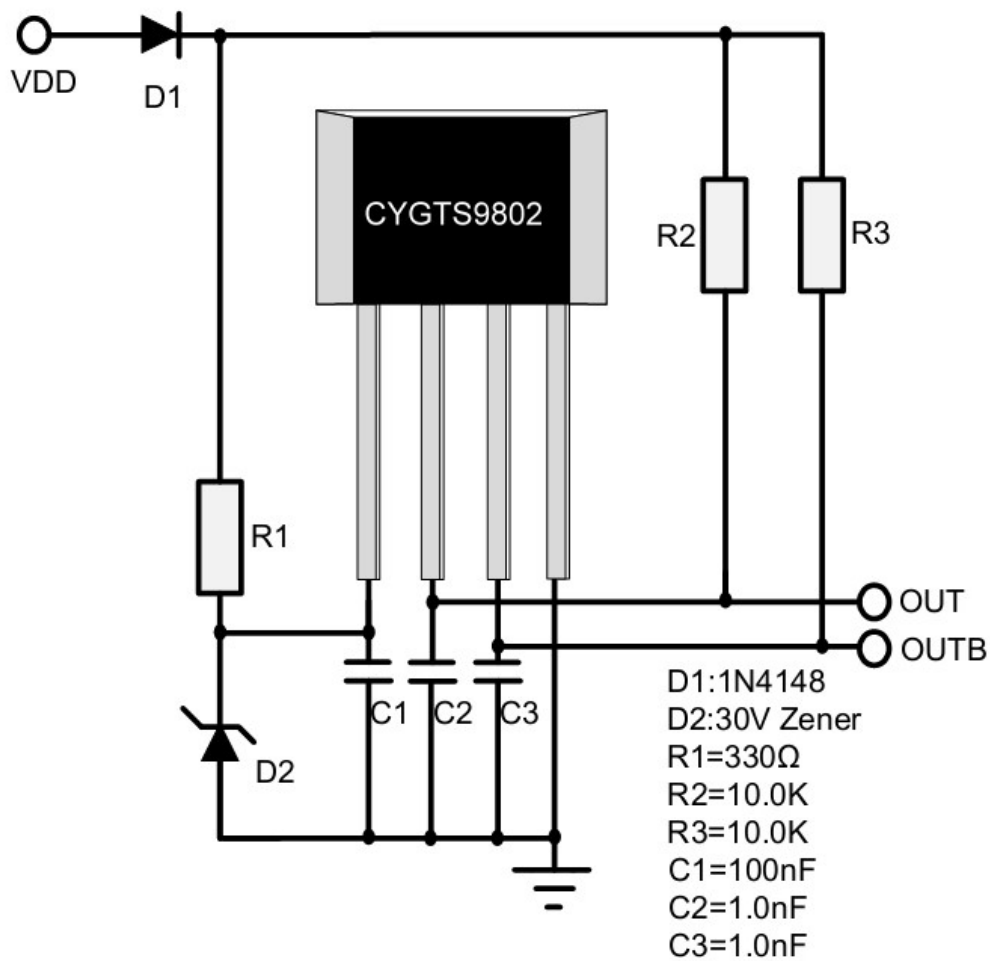

Number	Name	Function
1	VDD	Connects power supply to chip
2	OUT	Signal Output
3	OUTB	Complementary Signal Output
4	GND	Ground terminal

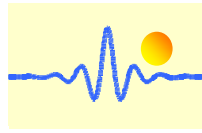

## Block Diagram

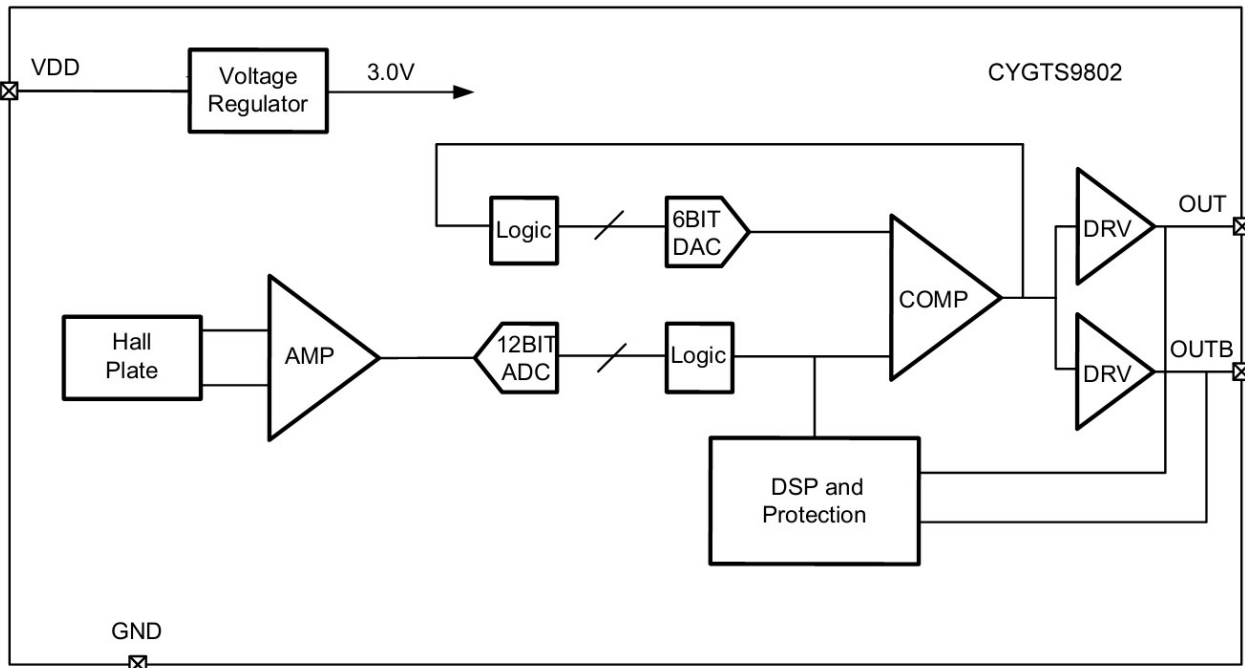

## Gear Tooth Sensing

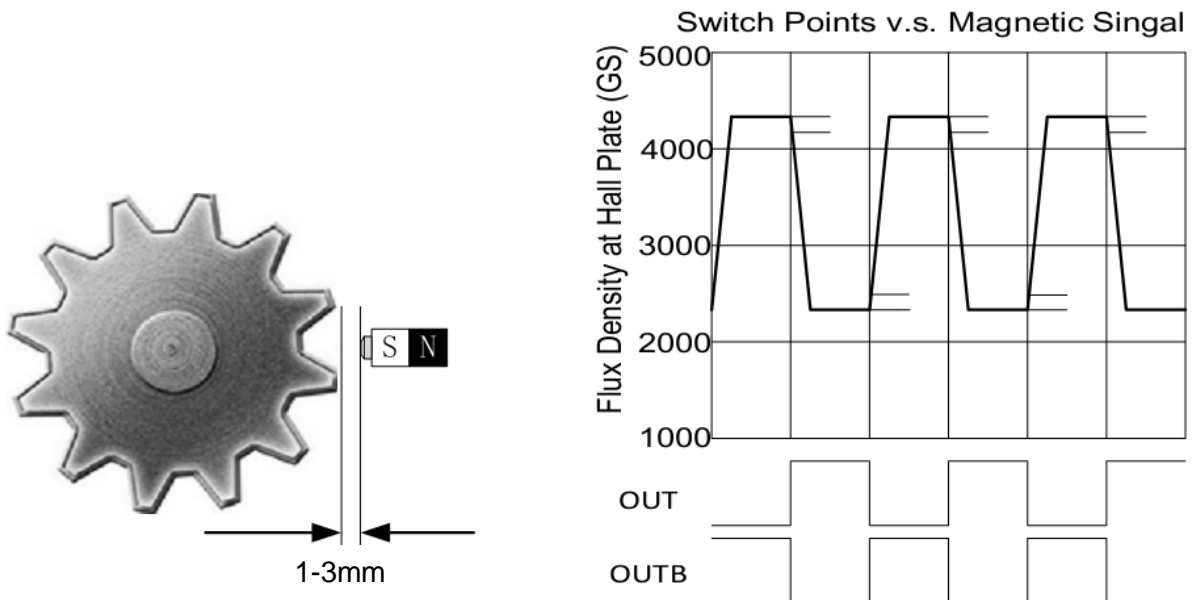

In the case of Ferromagnetic toothed wheel application the IC has to be biased by the south pole of a permanent magnet (Maximum 4000Gs). When assembling the sensor system, suggest to choose a magnet as back bias flux from 1000Gs to 4000Gs. Normally the South pole of magnet faces the unbranded side of the IC. The magnet should be glued to the back surface (non branded side) of the IC using a adhesive or suitable epoxy. The sensor CYGTS9802 is "Self adjusting" over a wide range of back bias flux eliminating the need for any trimming in the application. At the chip

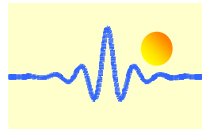

power on state, the output is reset to the high state whatever the field is. The output only changes after the first min is detected. The reset state holds no information about the field. If the supply of the chip is raised slowly, the reset state is not stable; the output maybe can't set to the high state. The maximum air gap depends on

- the magnetic field strength (magnet used; pre-induction) and
- the toothed wheel that is used (dimensions, material, etc.)

It is strongly recommended that an external ceramic bypass capacitor in the range 10nF to 1uF be connected between the supply and ground of the device to reduce external noise. The series resistor in combination with the bypass capacitor creates a filter for EMC pulse. The pull-up resistor should be chosen to limit the current through the output transistor; do not exceed the maximum continuous output current of the device.

### Physical Characteristics

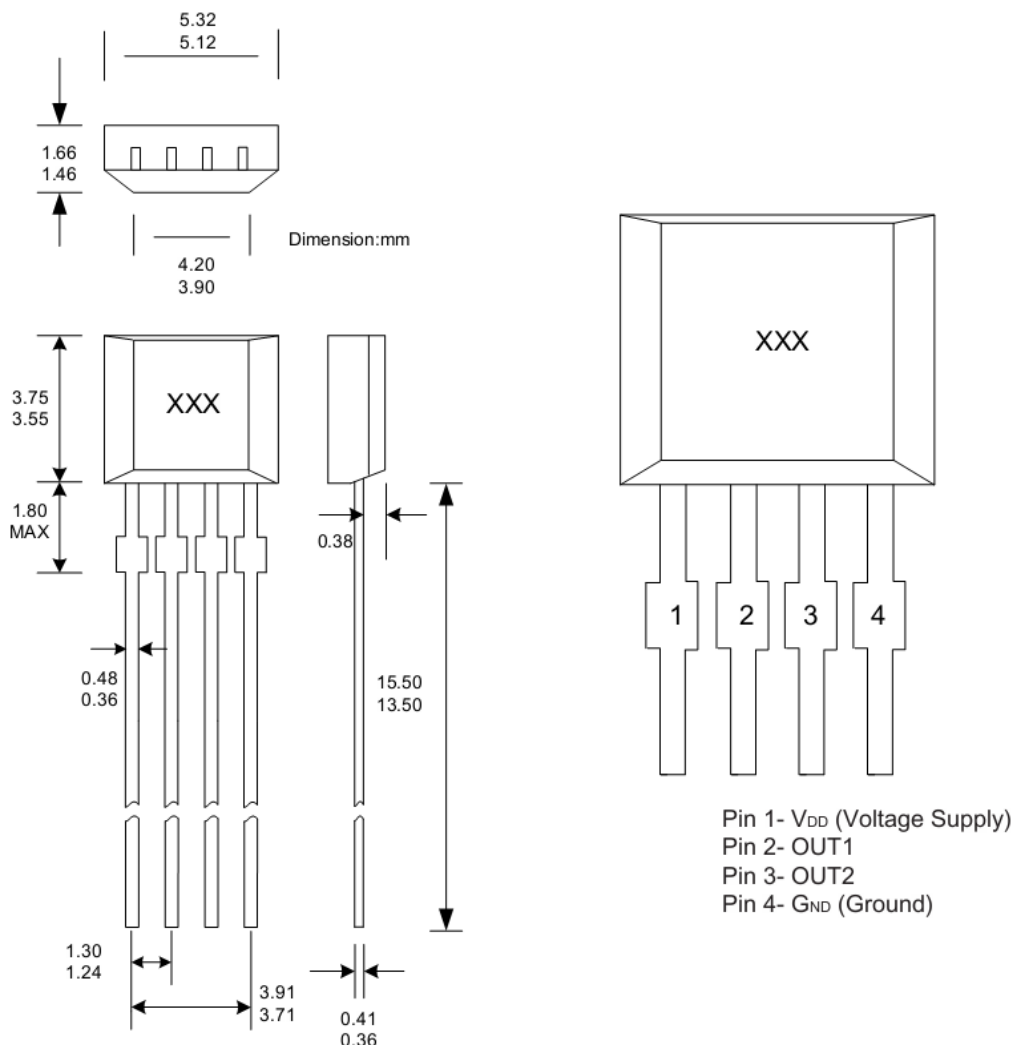

### Notes:

1. Exact body and lead configuration at vendor's option within limits shown.
2. Where no tolerance is specified, dimension is nominal.