

Dual Channel Sensitive Hall Effect Switch CYD8546

With Quadrature Outputs

The CYD8546 is a dual-channel, bipolar switch with two Hall Effect sensing elements, each providing a separate digital output for rotational speed measurement and direction detection. The Hall elements are photolithographically aligned to better than 1µm. Maintaining accurate mechanical location between the two active Hall elements eliminates the major manufacturing hurdle encountered in fine-pitch detection applications. The CYD8546 is a highly sensitive, temperature stable magnetic sensing device, which is ideal for use in ring magnet based speed and direction systems located in harsh automotive and industrial environments.

The Hall elements of the sensor CYD8546 are spaced 0.95mm apart, which provides excellent speed and direction information for small-geometric targets. Extremely low-drift amplifiers guarantee symmetry between the switches to maintain signal quadrature. An on-chip regulator allows the use of this device over a wide operating voltage range of 2.5V to 24V.

The CYD8546 is available in a 4-pin SIP package. The package is lead (Pb) free, with 100% matte tin leadframe plating.

Features

- Two matched Hall switches on a substrate
- Dual channel outputs
- Good temperature stability
- High sensitivity (B_{OP} and B_{RP})
- 2.5V to 24V supply voltage
- Reverse voltage protection
- Built-in pull-up resistor
- RoHS compliant

Applications

- Anti-pinch electric motor control
- Motor and fan control
- Magnetic encoder
- Rotating shaft monitoring
- Auto-motive transmission position
- Garage door openers
- Power sliding doors
- Sunroofs motors

Device information

Part number	Packing	Mounting	Temperature	B_{OP} (typ.)	BRP (Typ.)
CYD8546VB	Bulk, 1000pcs/bag	4-pin SIP	-40°C~150°C	+2.0mT	-2.0mT

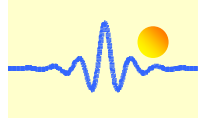

Electrical Specifications

Over operating free-air temperature range ($V_{DD} = 5.0V$, unless otherwise specified)

Symbol	Parameter	Test Conditions	Min.	Typ.	Max.	Units
V_{DD}	Operating supply voltage	$T_J < T_{J(max)}$	2.50	--	24	V
I_{DD}	Operating supply current	$V_{DD}=2.5$ to 24V	1.5	3.0	4.5	mA
t_{on}	Power on time		--	35	50	μs
I_{OL}	Off-state leakage current	Output Hi-Z	--	--	1	μA
R_{up}	Internal Pull-up resistor		5.0	10	15	k Ω
$R_{DS(on)}$	FET on resistance	$V_{DD}=5V$, $I_o=10mA$, $T_A=25^\circ C$	--	20	--	Ω
t_d	Output delay time	$B=B_{RP}$ to B_{OP}	--	13	25	μs
t_r	Output rise time	$R1=1k\Omega$, $C_o=50pF$	--	--	0.5	μs
t_f	Output fall time	$R1=1k\Omega$, $C_o=50pF$	--	--	0.2	μs
f_{BW}	Bandwidth		40	--	--	kHz

Magnetic Specifications

Symbol	Parameter	Test Conditions	Min.	Typ.	Max.	Units
B_{OP}	Operating point	VB Package	1.0	2.0	3.0	mT
B_{RP}	Release point		-3.0	-2.0	-1.0	mT
B_{HYS}	Hysteresis		--	4.0	--	mT
B_o	Magnetic Offset	$B_o=(B_{OP}+B_{RP})/2$	--	0	--	mT

1mT = 10Gs

Absolute Maximum Ratings

Over operating free-air temperature range

Parameter	Symbol	Min	Max.	Unit
Supply Voltage	V_{DD}	-28	28	V
Output voltage	V_{OUT}	-0.5	28	V
Output Sink Current, I_{OUT}	I_{SINK}	0	30	mA
Operating Temperature Range	T_A	-40	150	$^\circ C$
Maximum junction temperature	T_J	-55	165	$^\circ C$
Storage Temperature Range	T_{STG}	-65	175	$^\circ C$

Note: Stresses above those listed here may cause permanent damage to the device. Exposure to absolute maximum rating conditions for extended periods may affect device reliability.

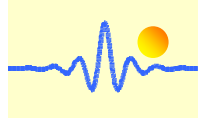

Thermal Characteristics

Symbol	Parameter	Test Conditions	Rating	Units
R _{QJA}	VB Package thermal resistance	Single-layer PCB, with copper limited to solder pads	177	°C/W

ESD Protection

Human body model (HBM) tests according to: Standard EIA/JESD22-A114-B HBM

Parameter	Symbol	Min.	Max.	units
ESD-Protection	V _{ESD}	-4	4	KV

Functional Diagram

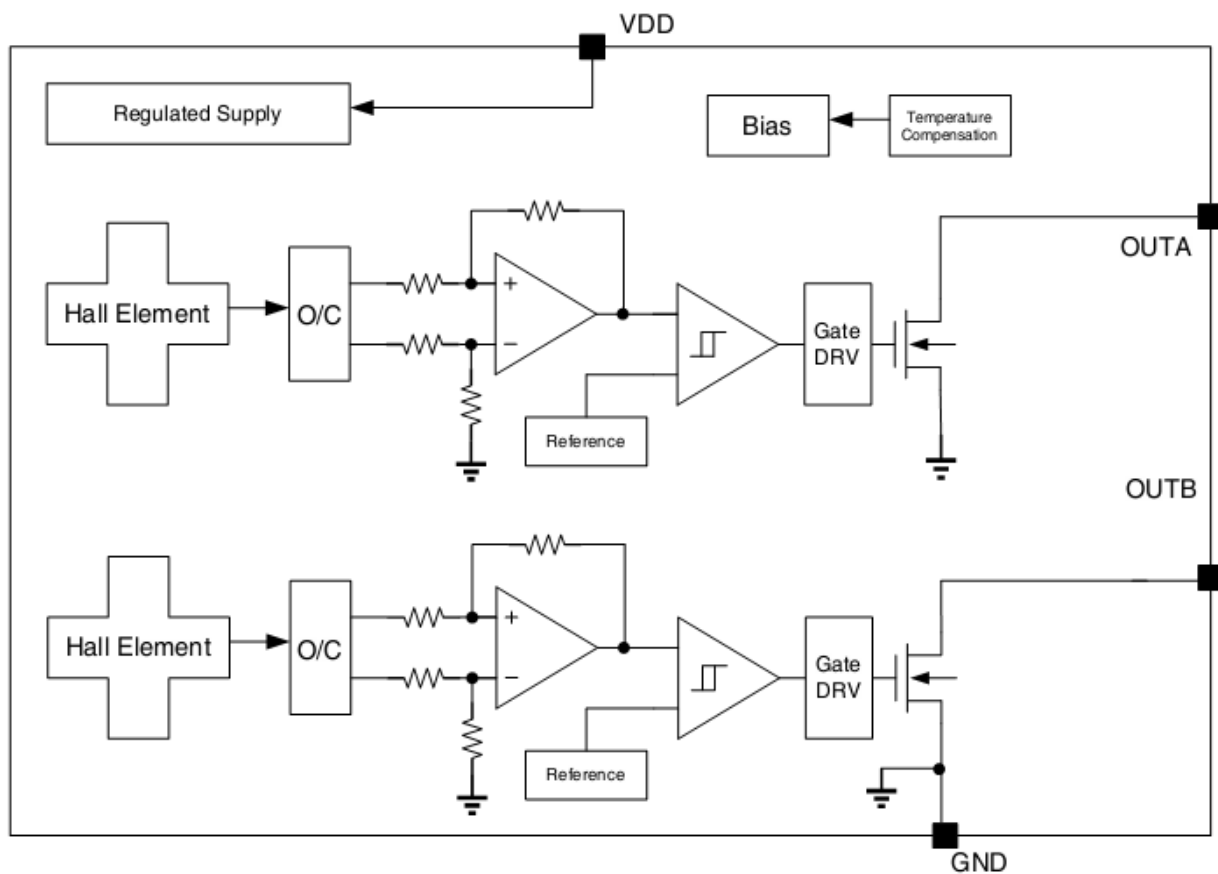

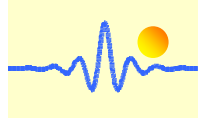

Terminal Configuration and Functions

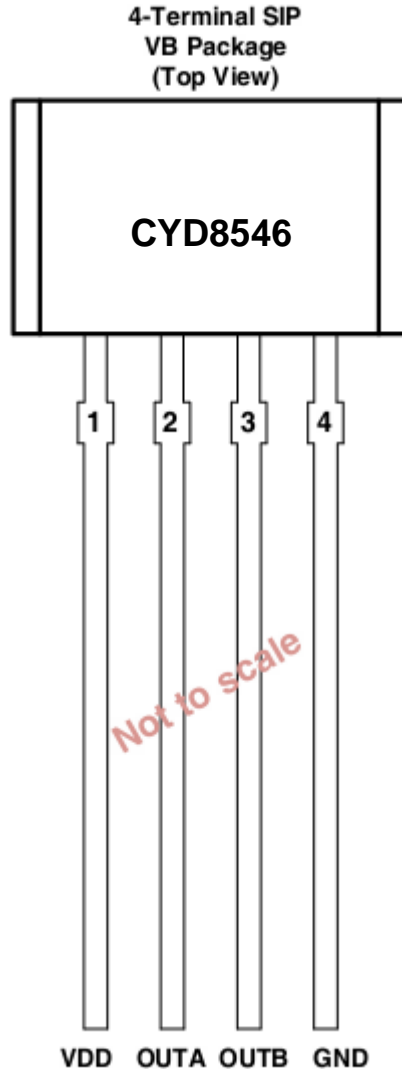

Pin Arrangement

Terminal		Type	Description
Name	Pin (VB Package)		
V _{DD}	1	Power supply	2.5V to 24V power supply
OUTA	2	Output A	A Channel output with internal pull-up resistor
OUTB	3	Output B	B Channel output with internal pull-up resistor
GND	4	Ground	Ground terminal

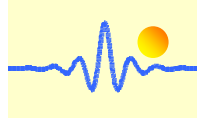

Characteristic Data

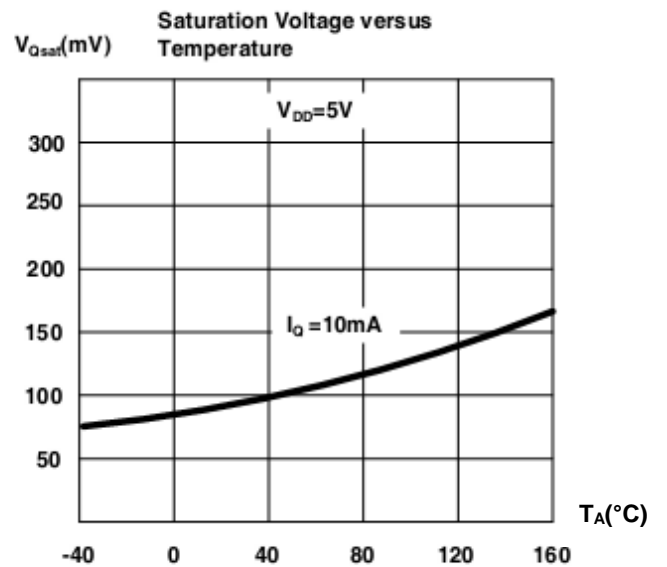
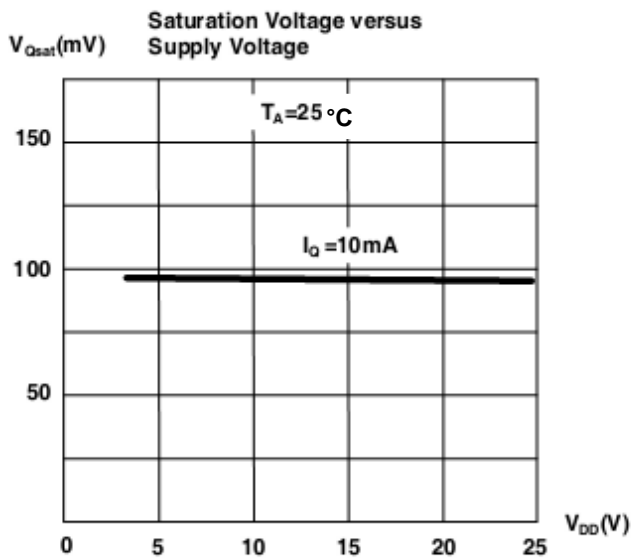
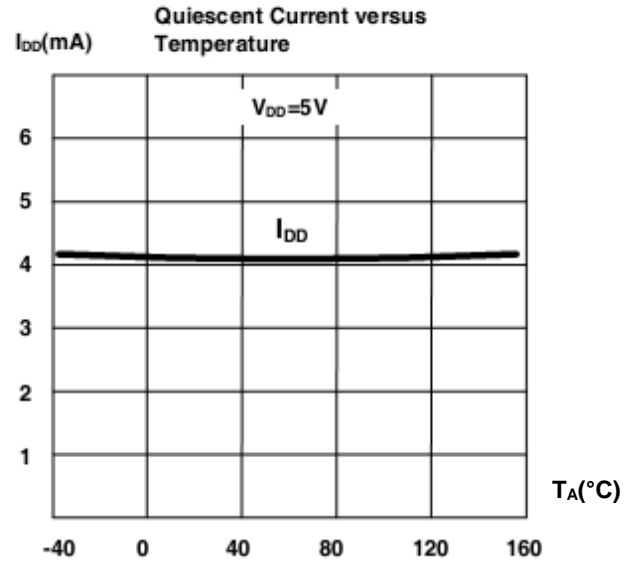
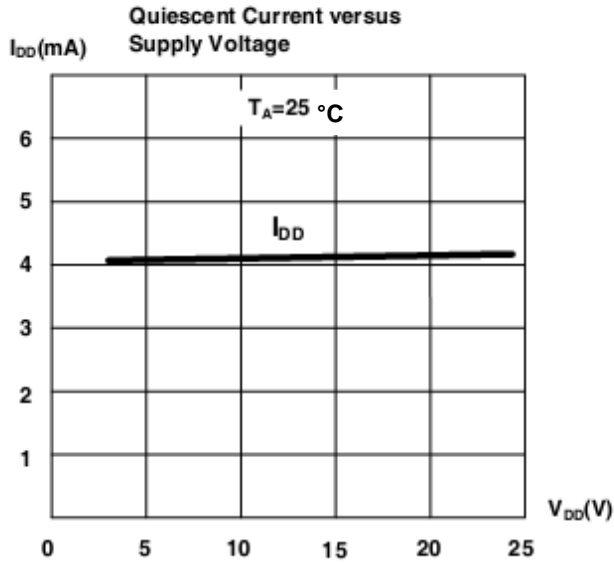

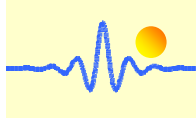

Characteristic Data (Continued)

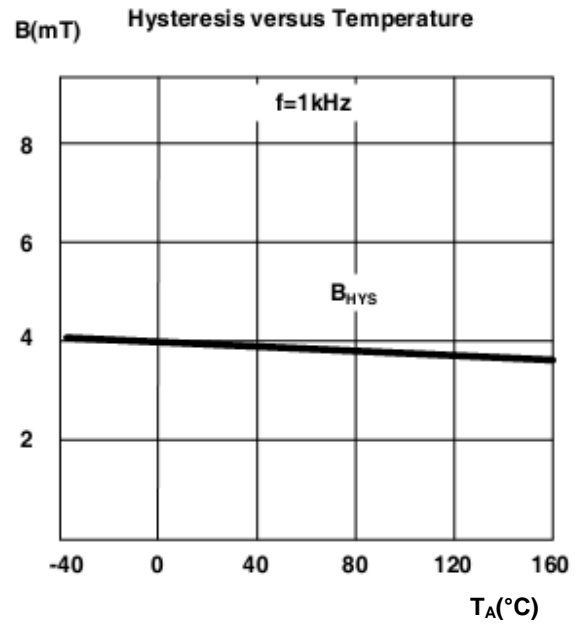
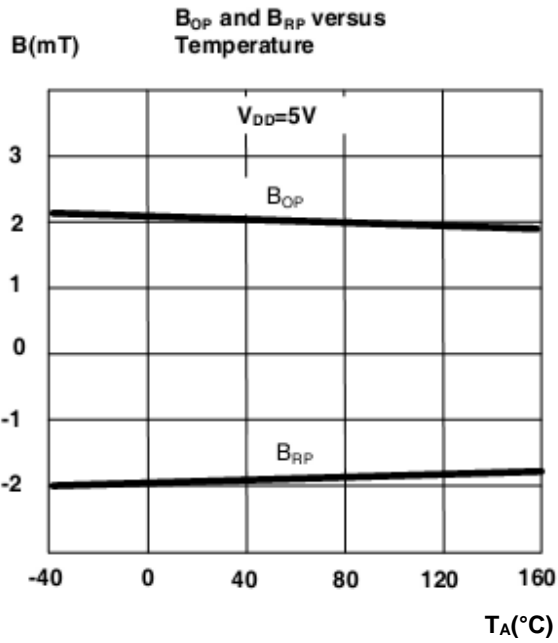

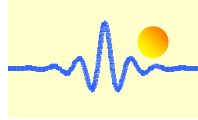

Typical Application Circuit

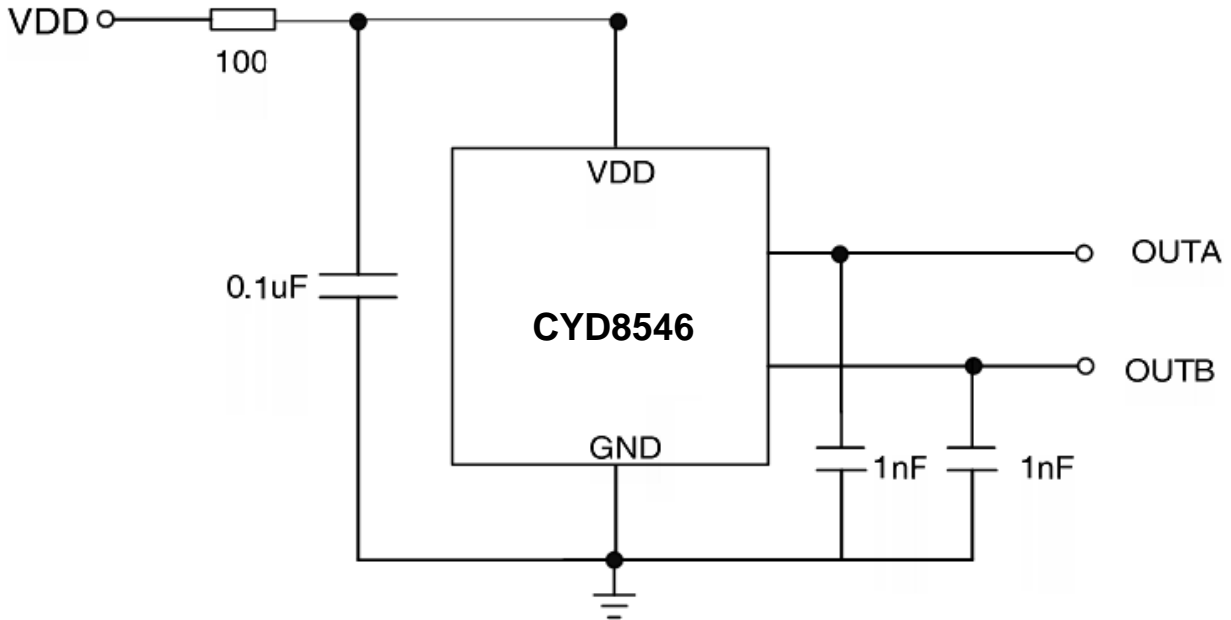

Typical Output Waveform

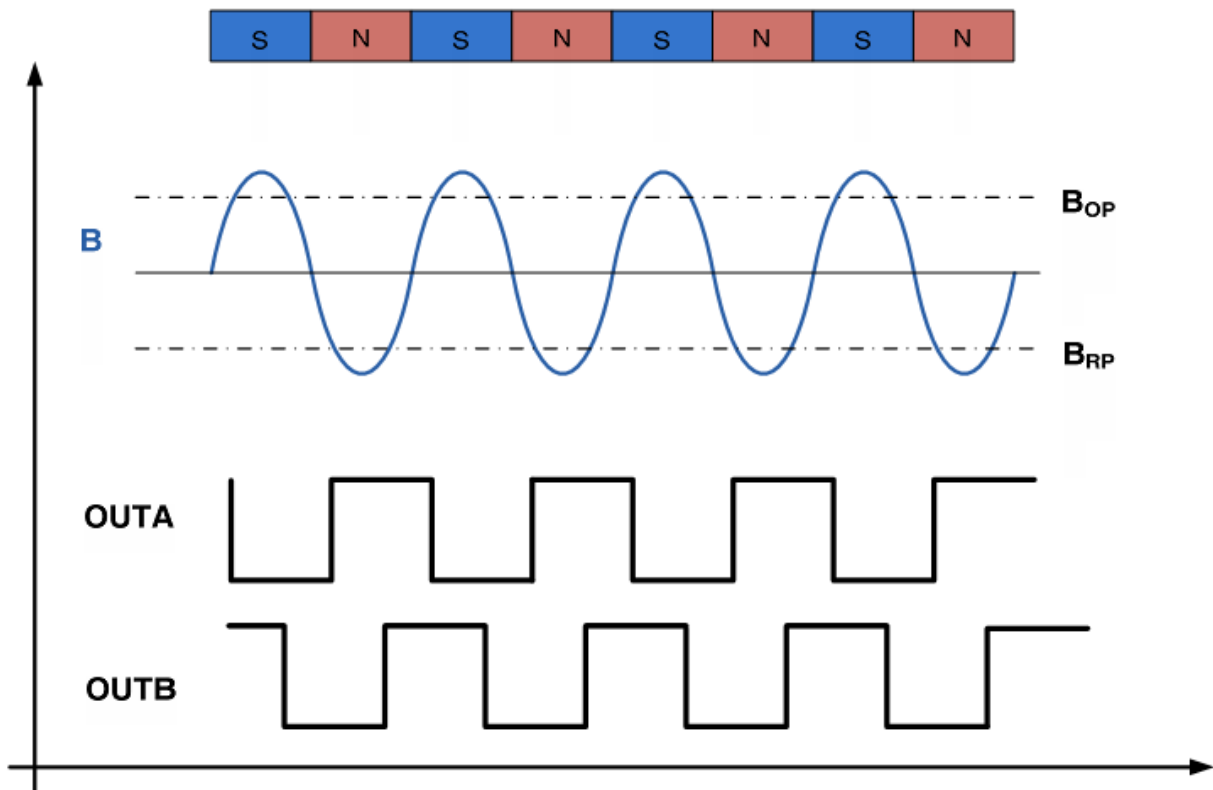

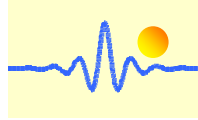

Geometric Dimensions (Package)

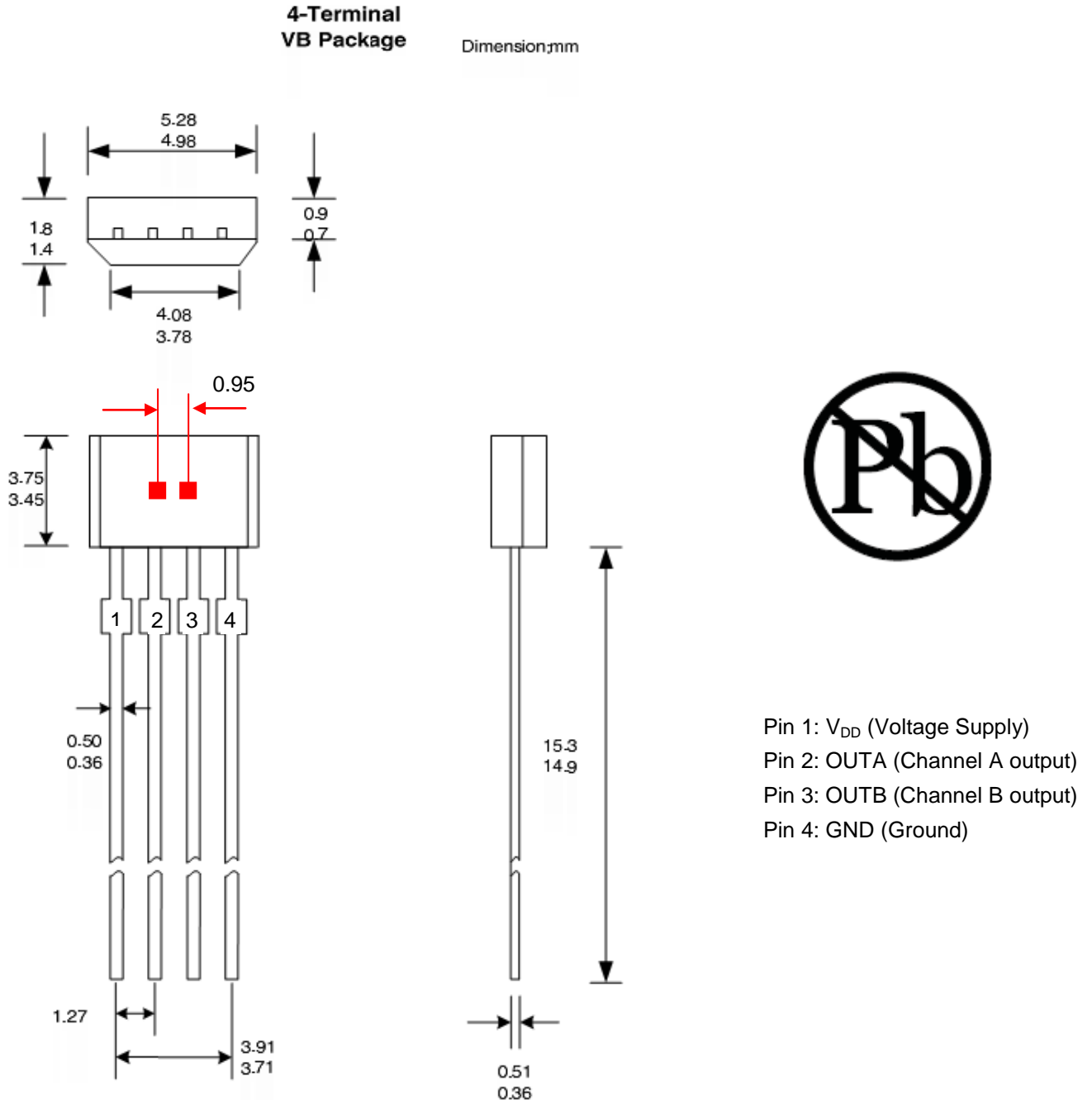

Notes:

1. Exact body and lead configuration at vendor's option within limits shown
 2. Height does not include mold gate flash
- Where no tolerance is specified, dimension is nominal