



## High-Sensitive Bipolar Hall Effect Switch CYD501

### Applications

- Brushless DC motors
- Speed measurement
- Counting
- Angle position detection
- Proximity detection
- Home applications
- Home safety etc.

### Features

- 2.7V to 30V operation voltage
- Overvoltage protection capability up to 40 V
- High accuracy bipolar switch
- Built-in dynamic offset cancellation
- Open drain output
- Low thermal drift of magnetic sensing
- Qualified according to AEC-Q100 test standard

### Package Type

P/N: CYD501-XX

TO92S (UA)



SOT23-3L (LH)

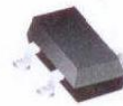

### Order Information

- CYD501-PA  
Package (PA): UA, LH

### Specifications

#### Absolute Maximum Ratings ( $T_A=25^\circ\text{C}$ )

Parameter	Symbol	Conditions	Rating	Unit
Maximum supply voltage	$V_{DDMAX}$		30	V
Operating temperature	$T_A$		-40~+150	$^\circ\text{C}$
Storage temperature	$T_S$		-40~+165	$^\circ\text{C}$
Maximum output current	$I_{OMAX}$		25	mA

#### Electrical Characteristics ( $T_A=25^\circ\text{C}$ , $V_{DD}=12\text{VDC}$ )

Characteristic	Symbol	Test Condition	Min.	Typ.	Max.	Unit
Supply voltage	$V_{DD}$		2.7		30	V
Supply current	$I_{DD}$	Output open		2.5	3.2	mA
Low output voltage	$V_{OL(ON)}$	@ $I_{OUT} = 20\text{mA}$		130	400	mV
Output leakage current	$I_{OH}$	Output switch off			0.1	$\mu\text{A}$
Output voltage	$V_{OUT}$				30	V
Output voltage fall time	$t_f$	$V_{DD}=12\text{V}$ ; $R_L=820\Omega$ ; $C_L=20\text{pF}$			1	$\mu\text{s}$
Output voltage rise time	$t_r$				1	$\mu\text{s}$
Delay time	$t_d$			18		$\mu\text{s}$

#### Magnetic Characteristics ( $T_A=25^\circ\text{C}$ , $V_{DD}=12\text{VDC}$ )

Characteristic	Symbol	Test Condition	Min.	Typ.	Max.	Unit
Operating point (On point)	$B_{OP}$	Pullup resistor $R_L=1\text{k}\Omega$ , Load capacitor $C_L=20\text{pF}$		9		G
Release point (Off point)	$B_{RP}$			-9		G
Hysteresis	$B_{HYS}$				18	G
Temperature coefficient	$T_C$				-1000	ppm/ $^\circ\text{C}$

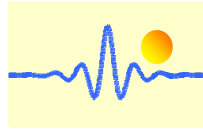

## General Specifications

CYD501 Hall Effect Switch is a monolithic integrated circuit which switches in response to magnetic field. If a magnetic field with flux lines perpendicular to the sensitive area is applied to the sensor, the biased Hall plate forces a Hall voltage proportional to this field. The Hall voltage is compared with the actual threshold level in the comparator. If the magnetic field exceeds the threshold levels, the output stage is switched to the appropriate state. The built-in hysteresis eliminates oscillation and provides switching behavior of output without bouncing.

Magnetic offset caused by mechanical stress is compensated by using the chopping offset compensation technique. A series resistor or diode on the supply line is not required thanks to the built-in reverse voltage protection.

The open drain output is forced to a safe, high-impedance state (tri-state), in any of the following fault conditions: overtemperature, and undervoltage. In addition, the output current is limited (short-circuit protection).

The device is able to withstand a maximum supply voltage of 28 V for unlimited time and features overvoltage capability (40V load dump). The architecture block diagram is shown in the following Fig.

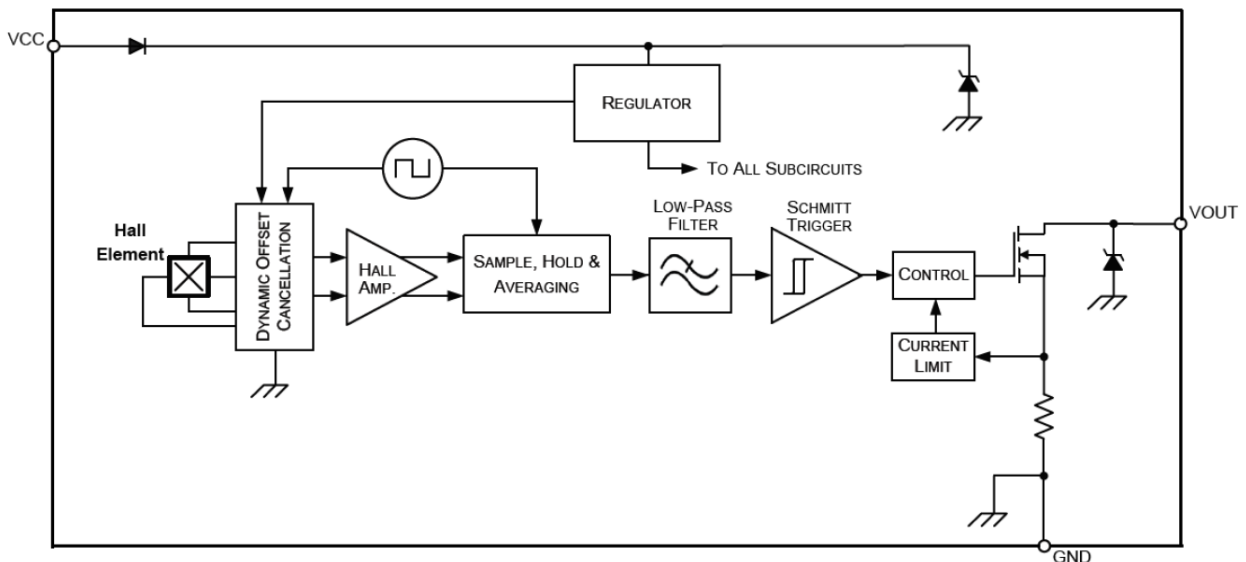

## Application Circuits

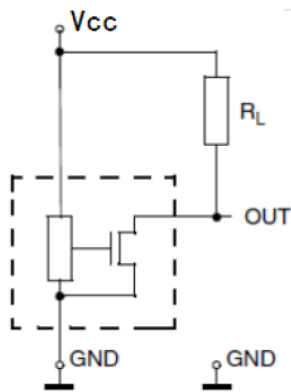

Circuit 1

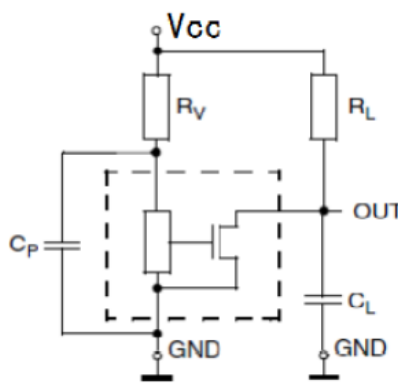

Circuit 2

For applications with disturbances on the supply line or radiated disturbances, a series resistor  $R_V$  and two capacitors  $C_P$  and  $C_L$ , all placed close to the sensor, are recommended.

For example:  
 $R_V = 100\Omega$   
 $C_P = 4.7 \text{ nF}$   
 $C_L = 1 \text{ nF}$   
 $R_L = 1\text{k} \sim 10\text{k} \Omega$



## Magnetic conversion instructions

Applying a South Pole magnetic field greater than  $B_{op}$  (Antarctic proximity) to the seal side of the TO92S package, the output becomes low; while a North Pole field near to the seal side the output becomes high. When the IC is first powered on, if the magnetic field is between  $B_{op}$  and  $B_{rp}$ , the output state will be in an undefined state (high or low).

The magnetic field polarity of the SOT23-3L package is the opposite of that of the TO92S. See figure below.

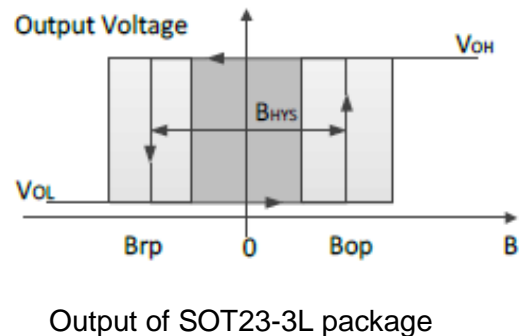
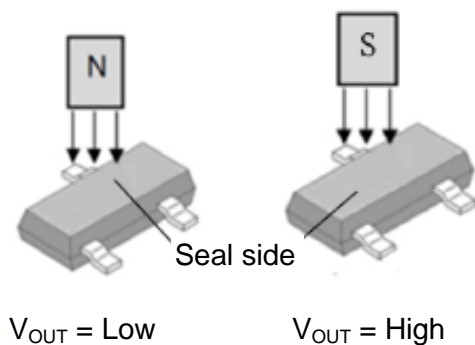
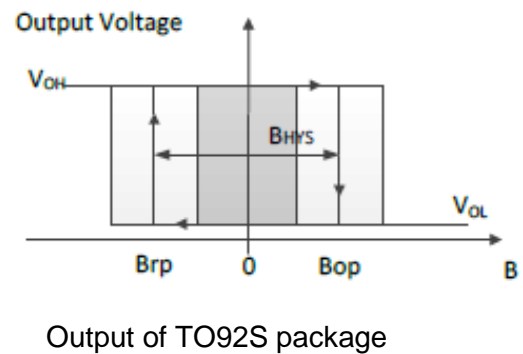
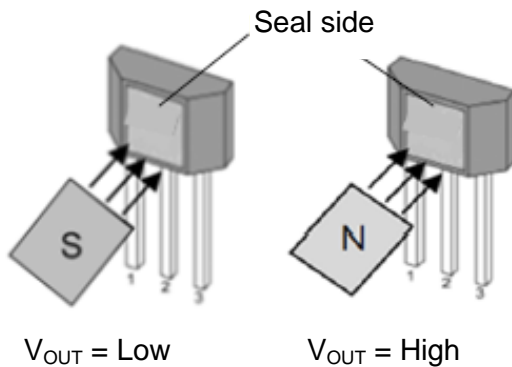

### Note:

Hall switch IC is a sensitive device and should be used and stored with care for electrostatic protection. The mechanical stress applied to the device housing and leads should be minimized during installation and use. It is recommended that the welding temperature should not exceed 350°C and the duration should not exceed 5 seconds. In order to ensure the safety and stability of Hall IC, it is not recommended to use out of parameter range for a long time.

### ESD Test

The output pin has to be in tri-state (high impedance) for ESD measurements

Symbol	Parameter	Min	Max	Unit
$V_{HBM}$	Human body model (according to AEC Q100-002)	-12	12	kV



**Package Outline**  
**T092S (UA)**

(Packing: bulk, 1000pcs/bag)

**Pin Assignment**

Pin No.	Name	Function
1	Vcc	Power supply
2	GND	Ground
3	Vout	Output

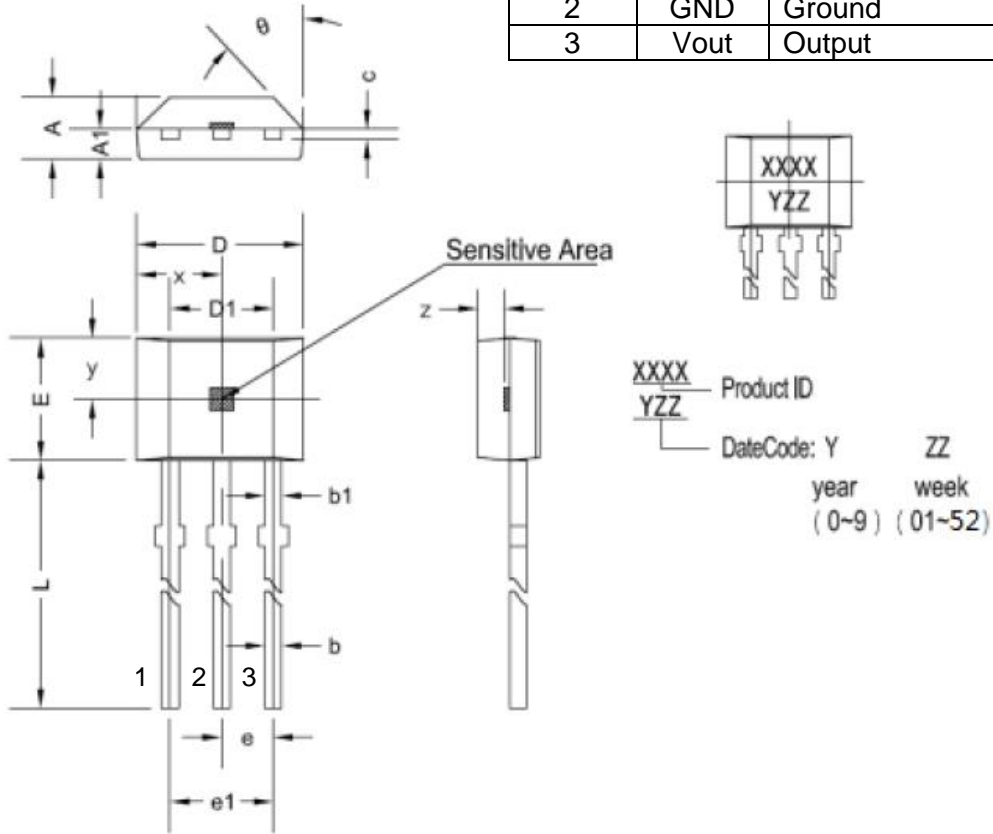

Symbol	Size (mm)		Size (inches)	
	Min.	Max.	Min.	Max.
A	1.42	1.67	0.056	0.066
A1	0.66	0.86	0.026	0.034
b	0.35	0.56	0.014	0.022
b1	0.40	0.55	0.016	0.022
C	0.36	0.51	0.014	0.020
D	3.90	4.20	0.154	0.165
D1	2.97	3.27	0.117	0.129
E	2.90	3.28	0.114	0.129
e	1.27 typ.		0.050 typ.	
e1	2.44	2.64	0.096	0.104
L	13.5	15.5	0.531	0.610
x	2.03 typ.		0.080 typ.	
y	1.55 typ.		0.061 typ.	
z	0.50 typ.		0.020 typ.	
θ	45° typ.		45° typ.	

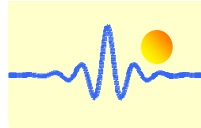

**Package Outline**  
**SOT23-3L(LH)**

(Packing: Tape&Reel, 3000pcs/reel)

**Pin Assignment**

Pin No.	Name	Function
1	Vcc	Power supply
2	GND	Ground
3	Vout	Output

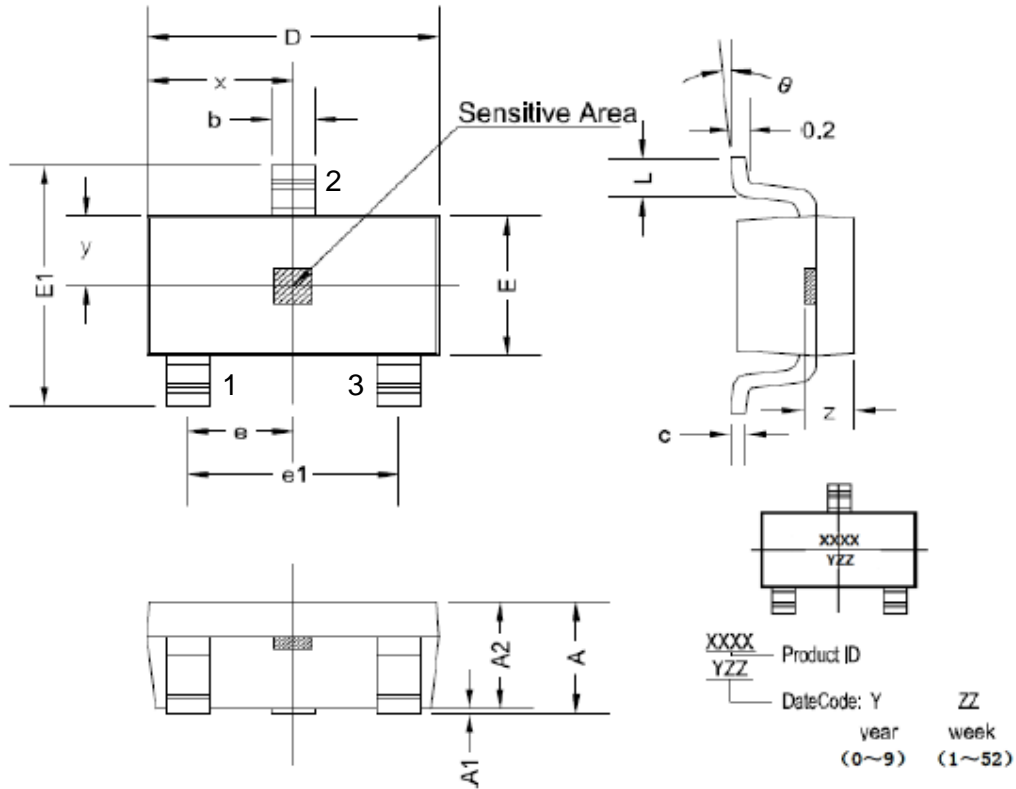

Symbol	Size (mm)		Size (in inches)	
	Min.	Max.	Min.	Max.
A	1.05	1.25	0.041	0.049
A1	0	0.10	0	0.004
A2	1.05	1.15	0.041	0.045
b	0.30	0.50	0.012	0.020
c	0.10	0.20	0.004	0.008
D	2.82	3.02	0.111	0.119
E	1.50	1.70	0.059	0.067
E1	2.65	2.95	0.104	0.116
e	0.95 typ.		0.037 typ.	
e1	1.80	2.00	0.071	0.079
L	0.30	0.60	0.012	0.024
x	1.46 typ.		0.057 typ.	
y	0.80 typ.		0.032 typ.	
z	0.60 typ.		0.024 typ.	
$\theta$	0°	8°	0°	8°